



Figure 1: Elstein HFS series

Elstein HFS panel radiators are ceramic infrared radiators, which are designed for medium surface ratings up to 38.4 kW/m² and operating temperatures up to 700 °C.

HFS series radiators are made using a hollow casting ceramic process. Compared to ceramic IR radiators produced using the full-pour casting process, HFS radiators have a considerably shorter heating-up time.

This technique was successfully used first for HFS radiators and then further developed for subsequent models.

HFS panel radiators are available in four designs and cover the power range from 60 W to 600 W.

Elstein HFS panel radiators have customary market dimensions and can therefore be replaced with radiators with the relevant properties if the requirements change.

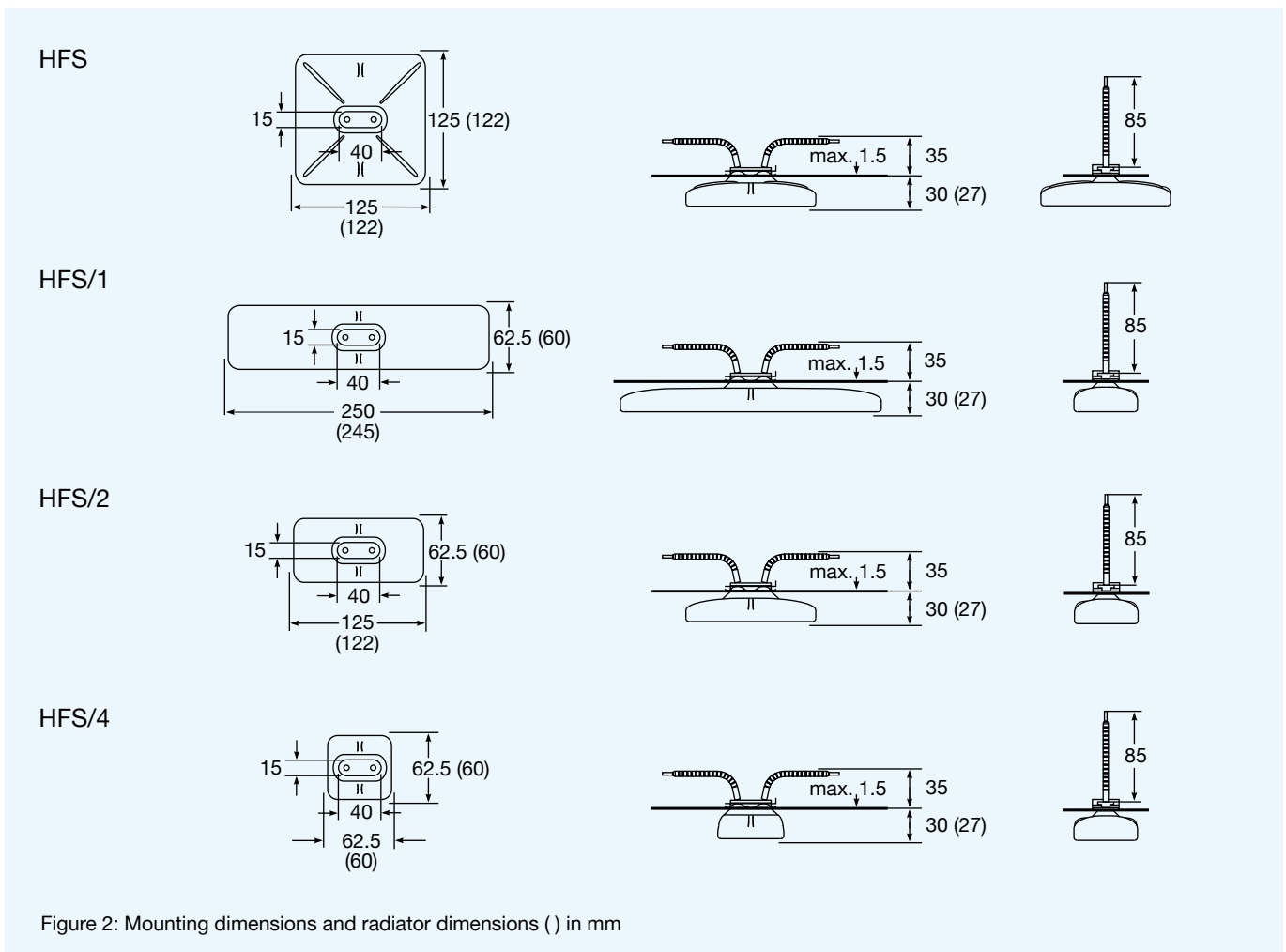
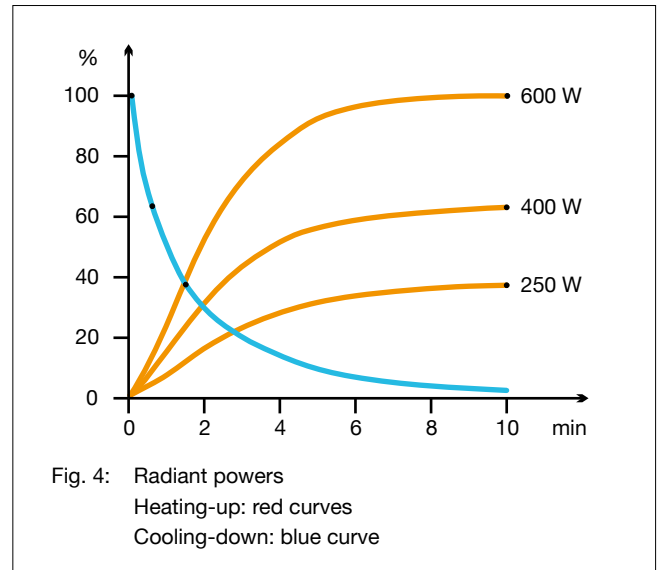
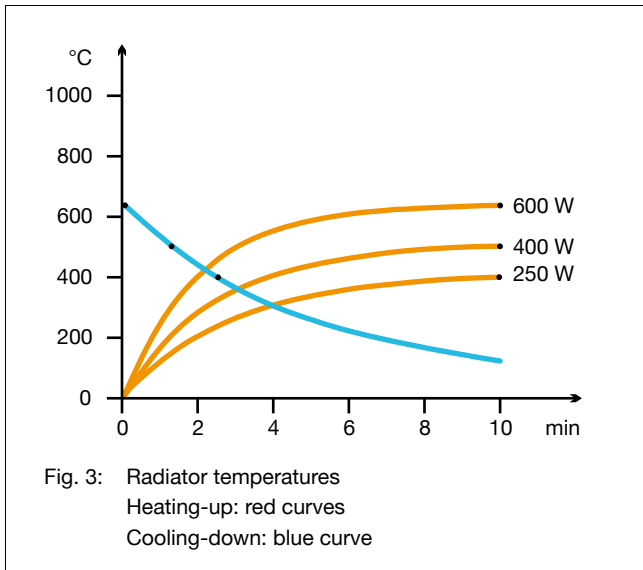

Figure 2: Mounting dimensions and radiator dimensions () in mm



Type, weight, wattage	HFS/1, HFS	220 g	250	400	600	W
	HFS/2	125 g	125	200	300	W
	HFS/4	75 g	60	100	150	W
Surface rating			16.0	25.6	38.4	kW/m ²
Typical operating temperature			420	510	630	°C
Maximum permissible temperature			700	700	700	°C
Wavelength range			2 - 10			µm

<p>Standard design</p> <p>Operating voltage 230 V Ceramic hollow casting White glaze Leads 85 mm Elstein standard socket Mounting set</p>	<p>Thermocouple radiators</p> <p>Designation T-HFS, T-HFS/1, T-HFS/2, T-HFS/4 Integrated thermocouple Type K (NiCr-Ni) TC leads 100 mm</p>	<p>Variants</p> <p>Special wattages Special voltages Extended leads Leads with ring terminals</p>
--	---	--

The power can be controlled using thermocouple radiators together with TRD 1 temperature controllers, TSE thyristor switching units and other accessories.

IR radiation areas can be assembled using REO reflectors, REF construction sets and MBO mounting sheets.

The national safety regulations must be complied with for the respective application, for example, the IEC or EN standard 60519-1, Safety in electrical heating installations.

Our instructions for mounting, operation and safety must be observed.