



Figure 1: Elstein HLF/S panel radiator

Elstein HLF/S panel radiators are ceramic infrared radiators, which can be used for operating temperatures up to 750 °C and surface ratings up to 64 kW/m².

Compared to other Elstein panel radiators the design of HLF/S-radiators is characterised by a heightened back with an extended socket.

HLF/S panel radiators are used in heating panels or machines, which are designed for the model of HLF/S radiators.

Since the Elstein HTS series with integrated thermal insulation was developed the HTS radiators represent the industrial state-of-the-art and are preferred for implementing projects of new machines and plants.

Elstein HLF/S panel radiators cover the power range from 250 W to 1000 W.

HLF/S

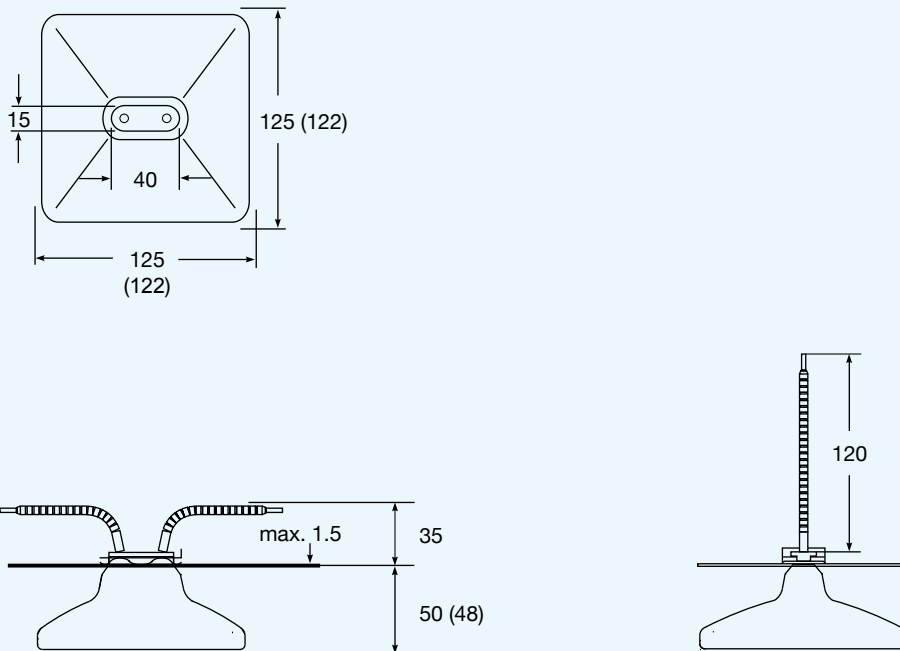
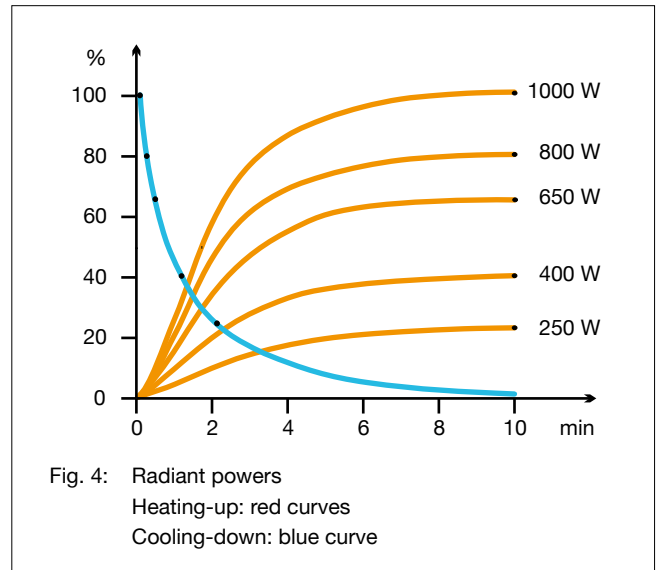
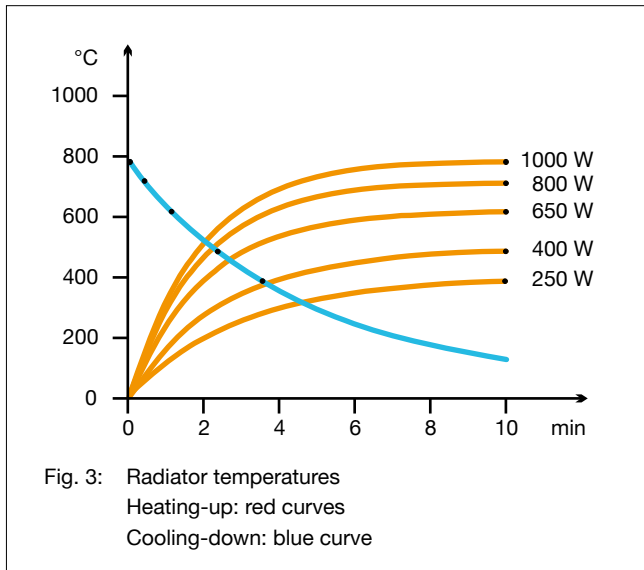

Figure 2: Mounting dimensions and radiator dimensions () in mm



Type, weight, wattage	HLF/S	220 g	250	400	650	800	1000	W
Surface rating			16.0	25.6	41.6	51.2	64.0	kW/m ²
Typical operating temperature			420	530	660	700	720	°C
Maximum permissible temperature			750	750	750	750	750	°C
Wavelength range			2 - 10					µm

<p>Standard design</p> <p>Operating voltage 230 V Ceramic hollow casting White glaze Leads 120 mm Elstein standard socket Mounting set</p>	<p>Thermocouple radiators</p> <p>Designation T-HLF/S Integrated thermocouple Type K (NiCr-Ni) TC leads 120 mm</p>	<p>Variants</p> <p>Special wattages Special voltages Extended leads Leads with ring terminals</p>
---	--	--

The power can be controlled using thermocouple radiators together with TRD 1 temperature controllers, TSE thyristor switching units and other accessories.

The national safety regulations must be complied with for the respective application, for example, the IEC or EN standard 60519-1, Safety in electrical heating installations.

Our instructions for mounting, operation and safety must be observed.