



Figure 39: Elstein HTS series

Elstein HTS high temperature radiators are ceramic infrared panel radiators, which can be used for operating temperatures up to 860 °C and surface ratings up to 64 kW/m².

HTS series radiators are produced using a hollow-casting ceramic process and are filled with thermal insulation material. This improves the radiant power output to the material to be heated.

Furthermore, there is a significant reduction in heat dissipated in the wiring space, so that additional insulation of the heating area is usually not required.

Compared with IR radiators, which are produced using full-poured casting processes, HTS radiators have a considerably reduced heating-up time and, depending on the type of application, enable energy savings of up to 25 %.

Elstein HTS high temperature radiators are available in four designs and cover the power range from 60 W to 1000 W.

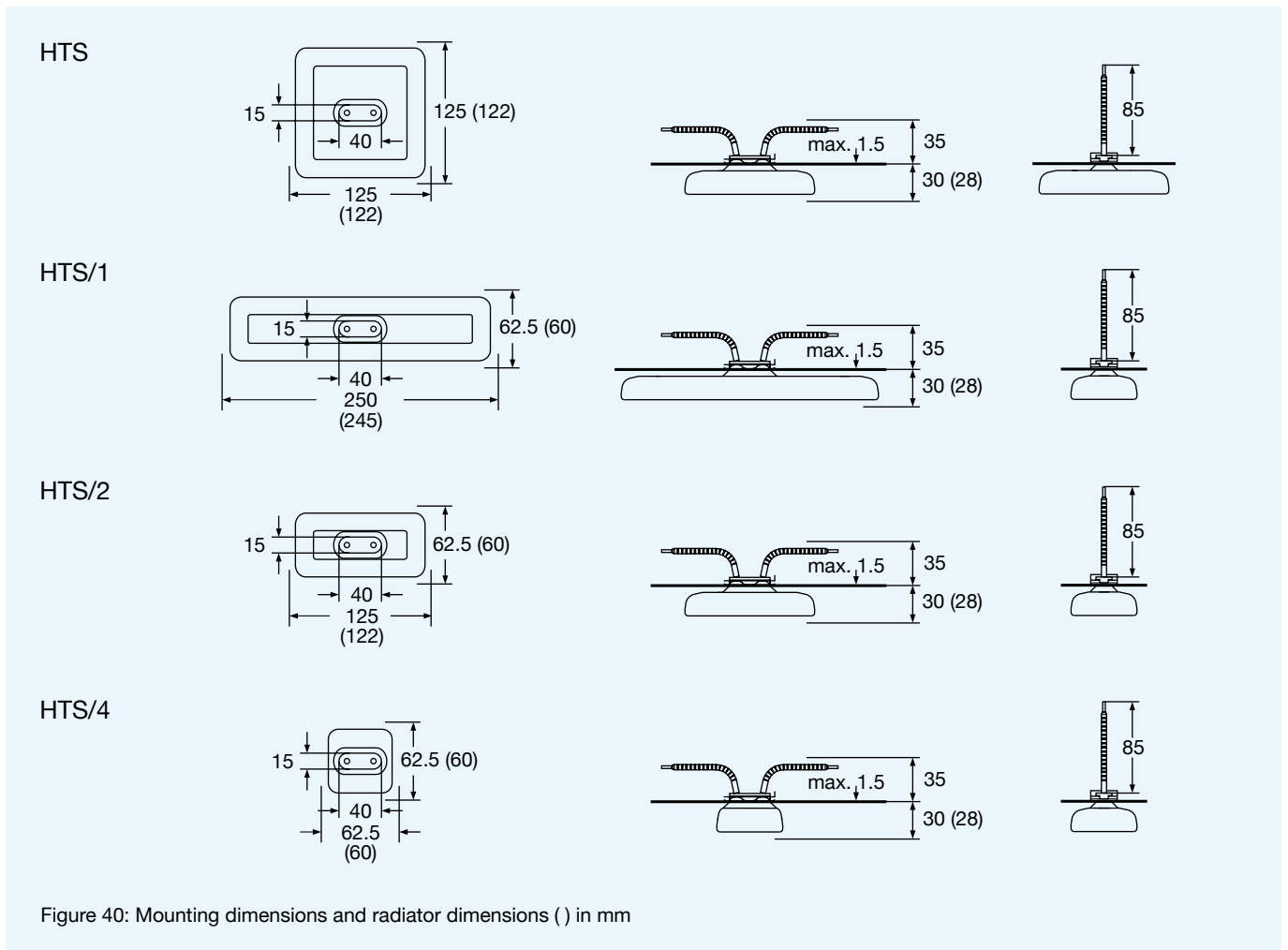
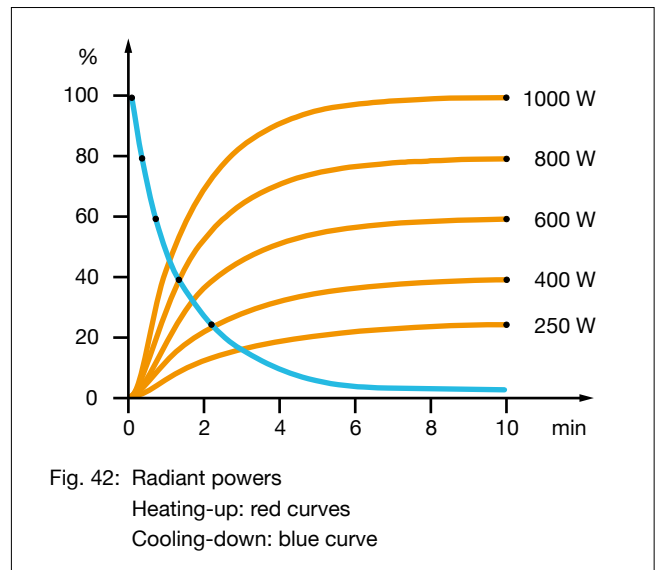
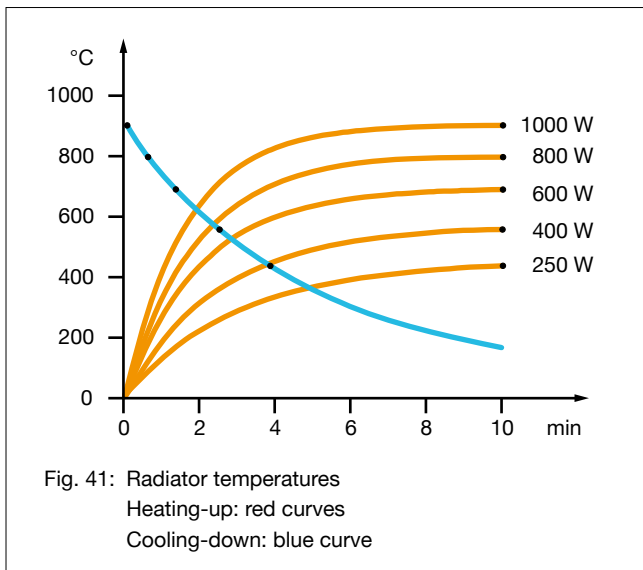

Figure 40: Mounting dimensions and radiator dimensions () in mm



Type, weight, wattage	HTS/1, HTS	220 g	250	400	600	800	1000	W
	HTS/2	125 g	125	200	300	400	500	W
	HTS/4	75 g	60	100	150	200	250	W
Surface rating			16.0	25.6	38.4	51.2	64.0	kW/m ²
Typical operating temperature			450	570	700	810	860	°C
Maximum permissible temperature			900	900	900	900	900	°C
Wavelength range			2 - 10					µm

Standard design	Thermocouple radiators	Variants
Operating voltage 230 V Ceramic hollow casting Integrated thermal insulation Leads 85 mm Elstein standard socket Mounting set	Designation T-HTS, T-HTS/1, T-HTS/2, T-HTS/4 Integrated thermocouple Type K (NiCr-Ni) TC leads 100 mm	Special wattages Special voltages Extended leads Leads with ring terminals

The power can be controlled using thermocouple radiators together with TRD 1 temperature controllers, TSE thyristor switching units and other accessories.

IR radiation areas can be assembled using REO reflectors, REF construction sets, EBF and EBI construction elements, MBO mounting sheets as well as BSH and BSI construction panels.

The national safety regulations must be complied with for the respective application, for example, the IEC or EN standard 60519-1, Safety in electrical heating installations.

Our instructions for mounting, operation and safety must be observed.