



Figure 1: Elstein SHTS/100

Elstein SHTS/100 super high temperature radiator is a ceramic infrared radiator, which has been designed for maximising the surface rating (W/m^2).

The surface rating of SHTS/100 is 80 kW/m^2 . It has a nominal output of 800 W and reaches an operating temperature of up to $860 \text{ }^\circ\text{C}$.

The Elstein SHTS/100 radiator has the dimensions $96 \times 96 \text{ mm}$ and is a special design of SHTS with the dimensions $122 \times 122 \text{ mm}$. Information about SHTS is available in our product catalog as well as download on the internet.

For building up infrared heating panels with SHTS/100 the MTO stainless steel mounting plates are available.

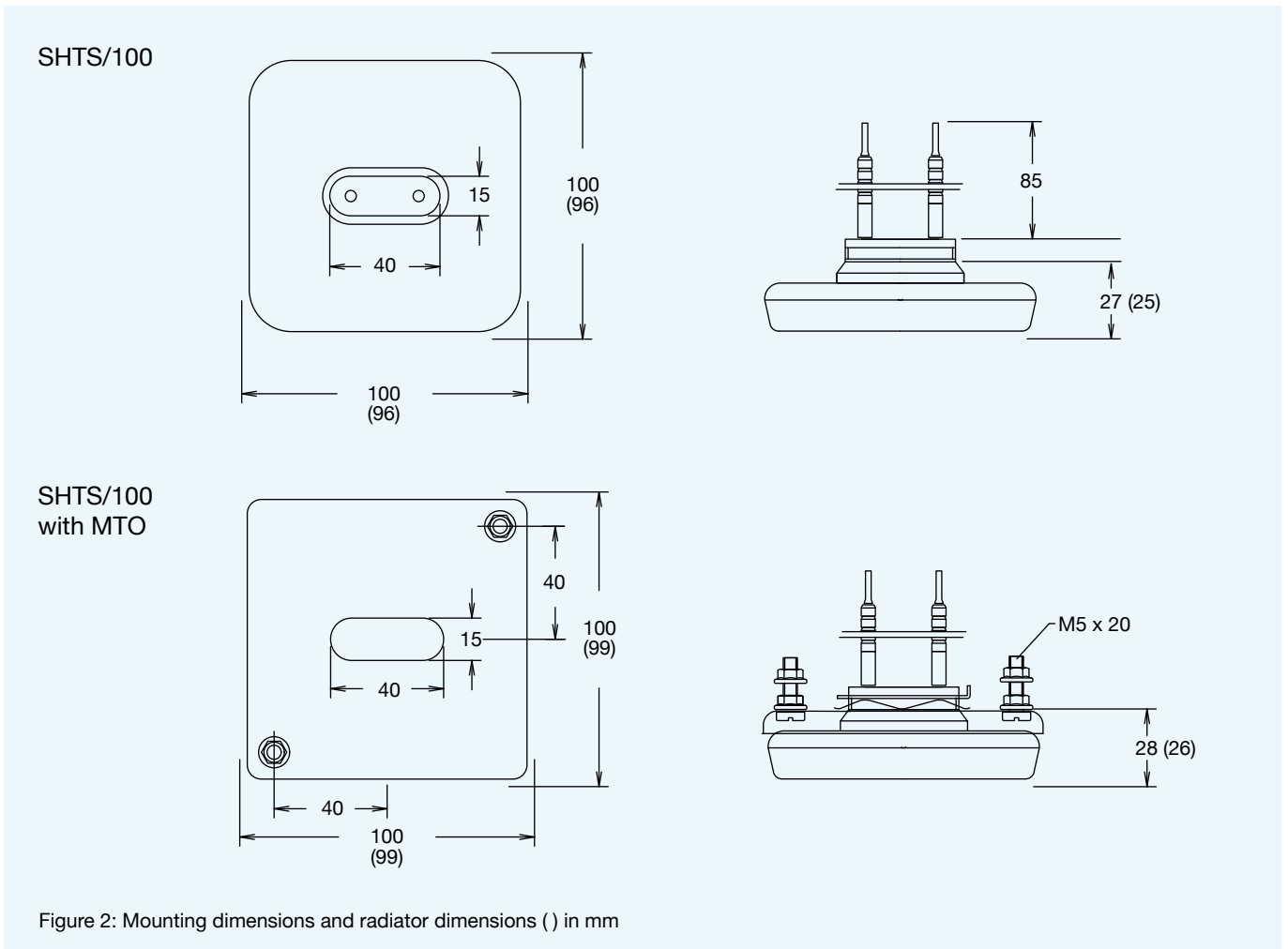

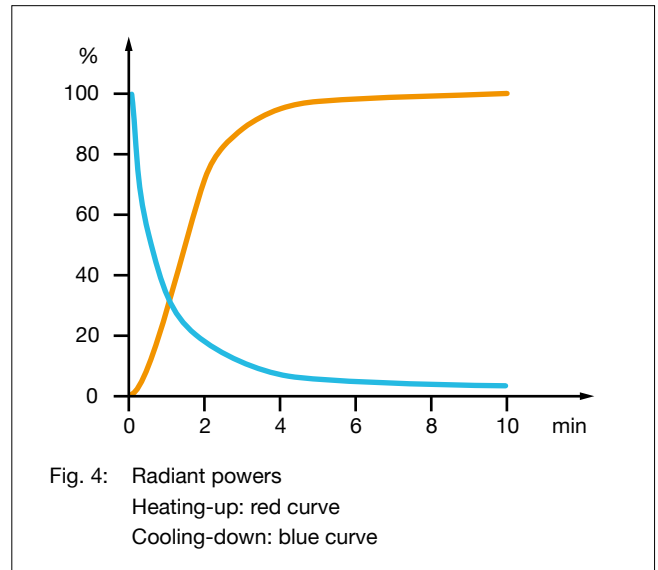
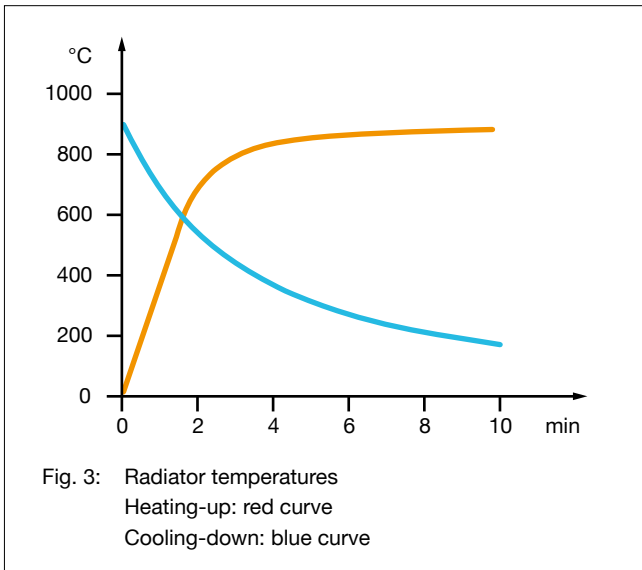

Type, weight, wattage	SHTS/100	170 g	800	W
Surface rating			80,0	kW/m ²
Typical operating temperature			860	°C
Maximum permissible temperature			900	°C
Wavelength range			2 - 10	µm

<p>Standard design</p> <p>Operating voltage 230 V Ceramic hollow casting Integrated thermal insulation Leads 85 mm Elstein standard socket Mounting set Special black glaze Gold-plated back</p>	<p>Thermocouple radiators</p> <p>Designation T-SHTS/100 Integrated thermocouple Type K (NiCr-Ni) TC leads 100 mm</p>	<p>Variants</p> <p>Special wattages Special voltages Extended leads Leads with ring terminals</p>
---	---	--

The power can be controlled using thermocouple radiators together with TRD 1 temperature controllers, TSE thyristor switching units and other accessories.

IR radiation areas can be assembled using MTO mounting bases.

The national safety regulations must be complied with for the respective application, for example, the IEC or EN standard 60519-1, Safety in electrical heating installations.

Our instructions for mounting, operation and safety must be observed.