



Figure 81: Elstein EBI construction element made from stainless steel, equipped with HTS/1

Elstein EBI construction elements are infrared radiation systems, whose housing parts are made from stainless steel. EBI systems are corrosion resistant and mechanically as well as thermally very stable. Therefore they are very suited for applications, where such requirements have to be fulfilled; for example in the food industry.

Elstein EBI construction elements are assembled in our factory. They can be equipped with Elstein ceramic panel radiators FSM, FSR, HTS/1, SHTS/1, HSR/1 and FSM/2, FSR/2, HTS/2, SHTS/2, HSR/2, whereby it is also possible to combine different radiator designs and wattages of the same types of radiators.

The user only has to do the wiring, fix the EBI elements in a steel section frame to be made on site and connect up with the electricity mains.

Elstein EBI construction elements are available in five lengths and can be fitted together to form radiation panels in any installed position as well as geometry.

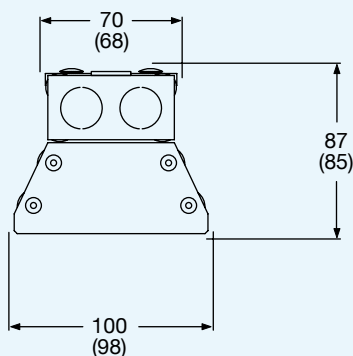
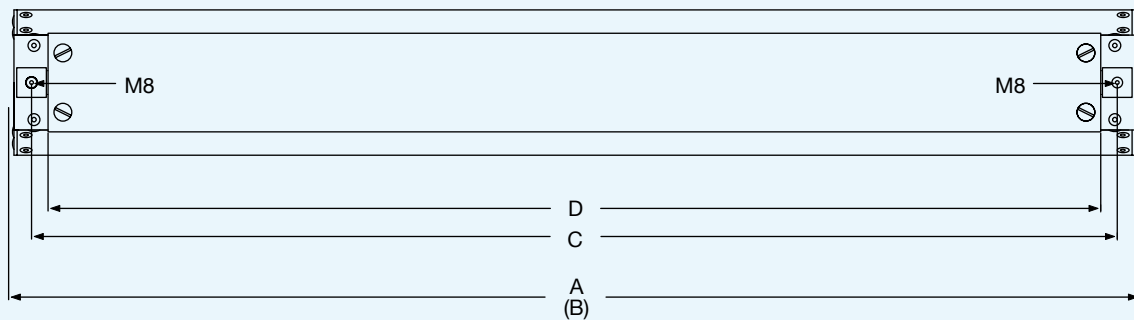

When exchanging EBF against EBI varying dimensions of housing and installation must be considered.

	A	B	C	D
EBI/25	260	257	233	210
EBI/50	515	508	484	461
EBI/75	765	759	735	712
EBI/100	1020	1010	986	963
EBI/125	1275	1261	1237	1214

Other lengths available on request
(from 125 mm to 2500 mm and longer)

Figure 82: Mounting dimensions and EBI dimensions () in mm

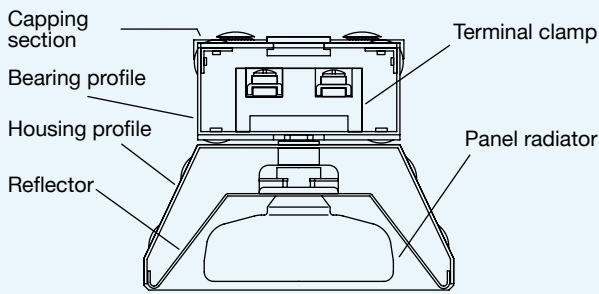

Fig. 83: Cross-section through an EBI construction element
Dimensions in mm



Fig. 84: Wiring space of an EBI construction element

400 W	400 W	400 W	400 W				
200 W	400 W	400 W	400 W	200 W			
300 W	400 W	400 W	400 W	300 W			
300 W	200 W	200 W	200 W	200 W	200 W	200 W	300 W

Fig. 85: Four examples of radiator equipment for an EBI/100 construction element



Fig. 86: EBI construction elements, screwed onto a section frame

Standard scope of delivery (variants and other lengths are available on request)

Ceramic infrared radiators, fitted, selectable heater types:

FSM, FSR, HSR/1, HTS/1, SHTS/1, FSM/2, FSR/2, HSR/2, HTS/2, SHTS/2

The maximum radiator power level available is 1200 W. Mixed radiator wattages and dimensions can be fitted.

Thermocouple radiators for temperature control are installed in the EBI construction element at the request of the customer. Accessories for controlling the temperature, such as the TRD 1 temperature controller and TSE thyristor switching units are included in the Elstein range of products.

REO reflectors for the radiator dimensions 245 mm x 60 mm and 122 mm x 60 mm, fitted

The REO reflectors are made from polished stainless steel. They are used for holding and fixing the radiators as well as reflecting the IR radiation in the direction of the material to be heated. On request, the reflectors fitted with ceramic infrared radiators are also available separately under the type designations REF/250 and REF/125.

Housing and bearing profiles, capping sections, appropriate end pieces, all made from stainless steel, fitted

For mounting the ceramic infrared radiators fixed to the REO reflectors. Each EBI consists of a housing profile with 2 end pieces, 1 bearing profile with 2 appropriate end pieces and a capping section. The end pieces of the bearing profile have 2 ring slits each. Cutting the land at the ring slit releases holes to insert M20 threaded joints for the electric power supply.

AK bipolar terminal clamps, fitted and connected with radiator power leads

For wiring the ceramic infrared radiators. The Elstein range of products includes accessories for the wiring, heat resistant flexible metal hoses and screw fitting accessories. The hoses are used to hold the nickel wire and thermo line and to protect them from mechanical stress.

Our instructions for mounting, operation and safety must be observed.